

# 24 0.72° HB

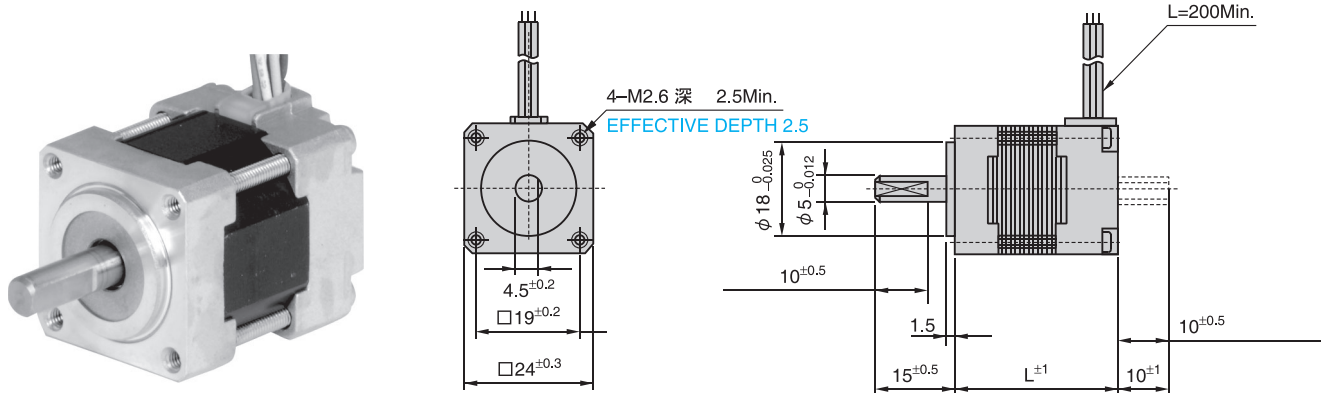

形式 Type number		額定電壓 Rated Voltage	額定電流 Rated Current	線圈阻抗 Winding Resistance	激磁最大 靜止力矩 Holding Torque	馬達長度L Motor Length	轉子慣量 Rotor Inertia	質量 Mass
單軸 Single Shaft	兩軸 Double Shaft	V/Phase	A/Phase	Ω/Phase	N·m(kgf·cm)	mm	g·cm <sup>2</sup>	g
TS3664N1E1	TS3664N11E1	1.58	0.35	4.5	0.017(0.17)	30.5	4.2	70
TS3664N1E2	TS3664N11E2	0.83	0.75	1.1	0.017(0.17)	30.5	4.2	70
TS3664N2E3	TS3664N12E3	2.35	0.35	6.7	0.028(0.28)	46.5	8.3	120
TS3664N2E4	TS3664N12E4	1.28	0.75	1.7	0.028(0.28)	46.5	8.3	120

- 使用周圍溫度 ———— -20~+50°C  
Operating temperature range
- 絕緣阻抗 ———— 100MΩ Min(at DC500V)  
Insulation resistance
- 絕緣耐壓 ———— AC500V(1min)  
Dielectric strength
- 軸心平行方向移動量 — 0.075mm Max.at the load 9.8N(1kgf)  
End play
- 軸心垂直方向移動量 — 0.025mm Max.at the load 4.9N(0.5kgf)  
Radial play
- 容許溫度上昇 ———— 80deg Max(Rasistance method)  
Permissible temperature rise

※注意:馬達表面請保持在90°C以下

※NOTE: Do not allow the surface temperature of the motor case to rise above 90°C during operation.

## 結線圖

### Wiring diagram

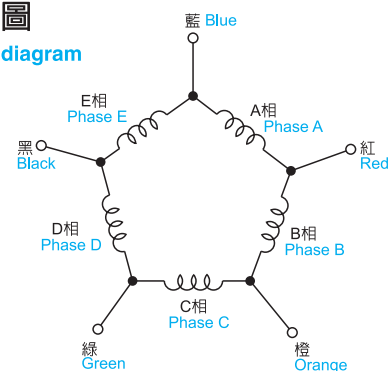

## 激磁順序

### Exciting sequence

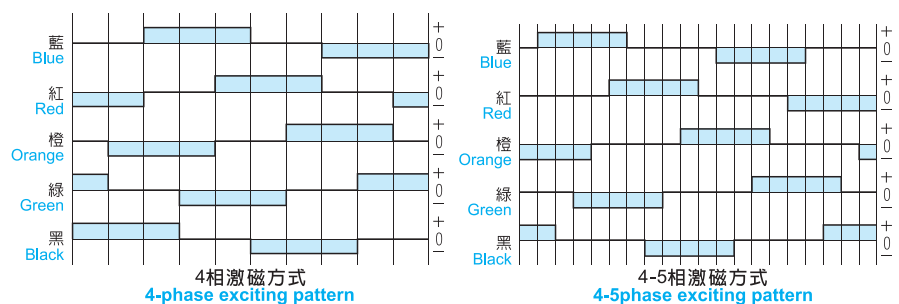

4相激磁方式  
4-phase exciting pattern

4-5相激磁方式  
4-5 phase exciting pattern