

20mm 0.72° HB

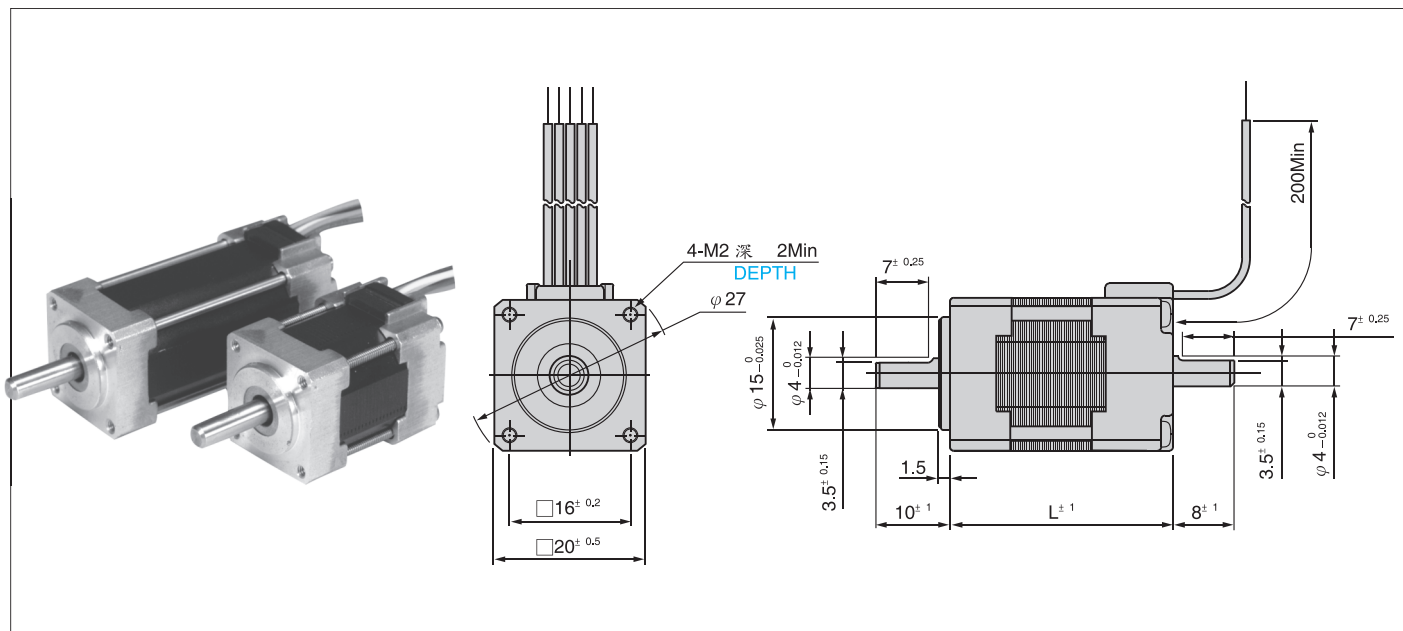

形式 Type number		基本步級角 Step Angle Deg.	額定電壓 Rated Voltage V/Phase	額定電流 Rated Current A/Phase	線圈阻抗 Winding Resistance Ω/Phase	激磁最大 靜止力矩 Holding Torque N-m(kgf·cm)	馬達長度L Motor Length mm	轉子慣量 Rotor Inertia g·cm ²	質量 Mass kg
單軸 Single Shaft	兩軸 Double Shaft								
TS3682N1	TS3682N11	0.72	2.1	0.35	6.1	0.013(0.13)	30	1.9	0.05
TS3682N41	TS3682N51	0.72	1.1	0.75	1.4	0.013(0.13)	30	1.9	0.05
TS3682N2	TS3682N12	0.72	4	0.35	11.4	0.024(0.24)	46.5	4	0.085
TS3682N42	TS3682N52	0.72	2	0.75	2.6	0.024(0.24)	46.5	4	0.085

- 使用周圍溫度 ———— -20~+50°C
Operating temperature range
- 絕緣阻抗 ———— 100MΩ Min(at DC500V)
Insulation resistance
- 絕緣耐壓 ———— AC500V(1min)
Dielectric strength
- 軸心平行方向移動量 — 0.075mm Max.at the load 9.8N(1kgf)
End play
- 軸心垂直方向移動量 — 0.025mm Max.at the load 4.9N(0.5kgf)
Radial play
- 容許溫度上昇 ———— 80deg Max(Rasistance method)
Permissible temperature rise

※注意:馬達表面請保持在90°C以下
 ※NOTE: Do not allow the surface temperature of the motor case to rise above 90°C during operation.

結線圖 Wiring diagram

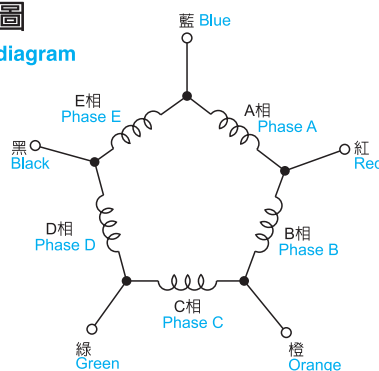

激磁順序 Exciting sequence

