

85 HB TYPE 高扭力・低振動

1.8°

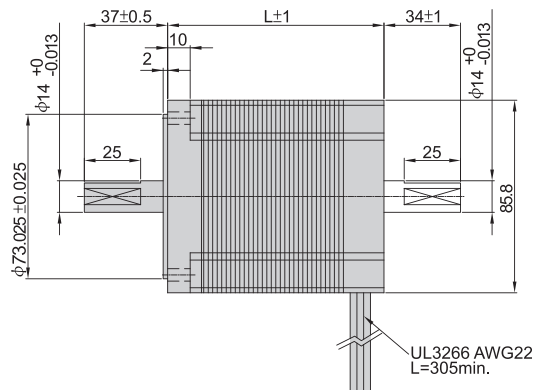
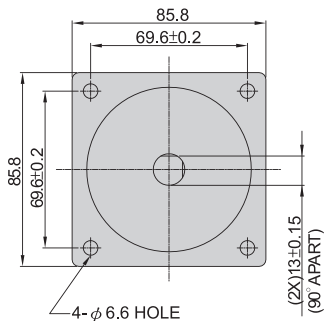
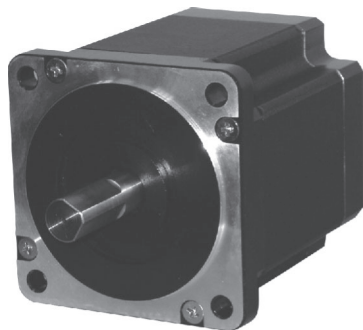

形式 Type number		基本步級角 Step Angle Deg.	額定電壓 Rated Voltage V/Phase	額定電流 Rated Current A/Phase	線圈阻抗 Winding Resistance Ω/Phase	線圈感抗 Inductance mH/Phase	激磁最大 靜止力矩 Holding Torque N-m(kgf·cm)	馬達長度L Motor Length mm	轉子慣量 Rotor Inertia x10 ⁻⁷ kg·m ²	重量 Weight g
單軸 Single Shaft	兩軸 Double Shaft									
EXMK296-02A	EXMK296-02B	1.8	4.4	2	2.2	8	2.2(22)	66	1400	1750
EXMK296-03A	EXMK296-03B	1.8	3	3	1	4	2.2(22)	66	1400	1750
EXMK296-04A	EXMK296-04B	1.8	2	4.5	0.48	1.7	2.2(22)	66	1400	1750
EXMK299-02A	EXMK299-02B	1.8	6.4	2	3.2	20	4.4(44)	96	2700	2800
EXMK299-03A	EXMK299-03B	1.8	4.2	3	1.5	6.6	4.4(44)	96	2700	2800
EXMK299-04A	EXMK299-04B	1.8	2.8	4.5	0.66	3	4.4(44)	96	2700	2800
EXMK2913-02A	EXMK2913-02B	1.8	7.6	2	3.8	2.5	6.6(66)	126	4000	3930
EXMK2913-04A	EXMK2913-04B	1.8	3.8	4	0.95	5.5	6.6(66)	126	4000	3930

- 使用周圍溫度 ———— -20~+50°C
Operating temperature range
- 絕緣阻抗 ———— 100MΩ Min(at DC500V)
Insulation resistance
- 絕緣耐壓 ———— AC500V(1min)
Dielectric strength
- 軸心平行方向移動量 — 0.075mm Max. (With 1kg Load)
End play

- 軸心垂直方向移動量 — 0.025mm Max. (With 500g Load)
Radial play
- 容許溫度上昇 ———— 80deg Max(Rasistance method)
Permissible temperature rise

※注意:馬達表面請保持在90°C以下
※NOTE: Do not allow the surface temperature of the motor case to rise above 90°C during operation.

結線圖 WIRING DIAGRAM

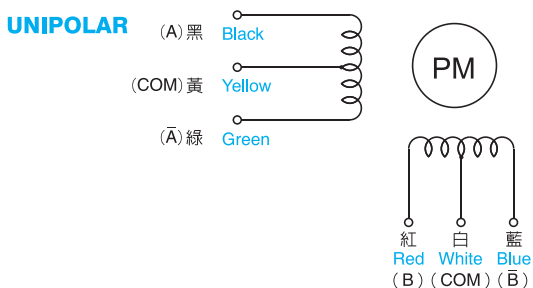

回轉方向：由出力軸目視之正轉方向
CW rotation from output shaft end.

Step	黑 Black	紅 Red	綠 Green	藍 Blue	黃 Yellow	白 White
0	ON	ON			COM	COM
1		ON	ON		COM	COM
2			ON	ON	COM	COM
3	ON			ON	COM	COM
0	ON	ON			COM	COM