

60

齒輪軸(GH)系列
HB TYPE GEAR TYPE

1.8° 強力型、正減速比

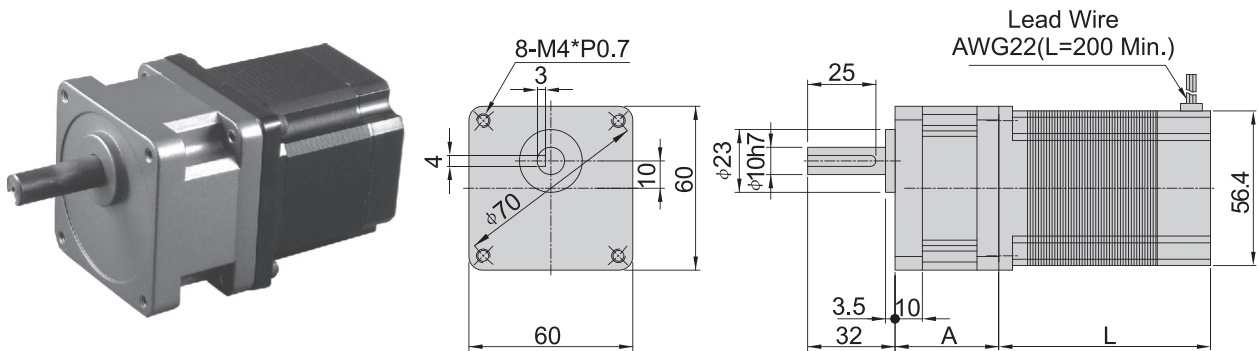

形式 Type number	基本步級角 Step Angle Deg.	額定電壓 Rated Voltage V/Phase	額定電流 Rated Current A/Phase	線圈阻抗 Winding Resistance Ω/Phase	線圈感抗 Inductance mH/Phase	激磁最大 靜止力矩 Holding Torque N-m(kgf·cm)	馬達長度L Motor Length mm	轉子慣量 Rotor Inertia x10 ⁻⁷ kg·m ²	質量 Mass kg
EXMK266-02GA-GH	1.8	3.6	2	2	3.2	0.8(8)	55	280	0.7
EXMK268-02GA-GH	1.8	4.5	2	2.25	3.8	1.3(13)	77.5	480	1

2GH□K規格表

減速比	3.6	7.2	10	20	30	50
容許轉矩 N.m(kgfcM)	4(40)	4(40)	4(40)	6(60)	6(60)	6(60)
容許推力載重 N(kg)	40(4)					
容許懸吊載重 N(kg)	100(10)					
齒隙 min(度)	35(0.583°)	15(0.25°)		10(0.167°)		
尺寸A mm	38			45.5		52.5

結線圖 WIRING DIAGRAM

UNIPOLAR

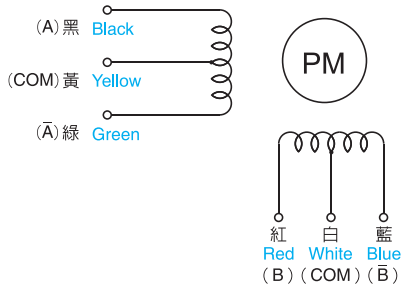

回轉方向：由出力軸目視之正轉方向
CW rotation from output shaft end.

Step	黑 Black	紅 Red	綠 Green	藍 Blue	黃 Yellow	白 White
0	ON	ON			COM	COM
1		ON	ON		COM	COM
2			ON	ON	COM	COM
3	ON			ON	COM	COM
0	ON	ON			COM	COM