



42

HB TYPE

高扭力 · 低振動

1.8°

High torque

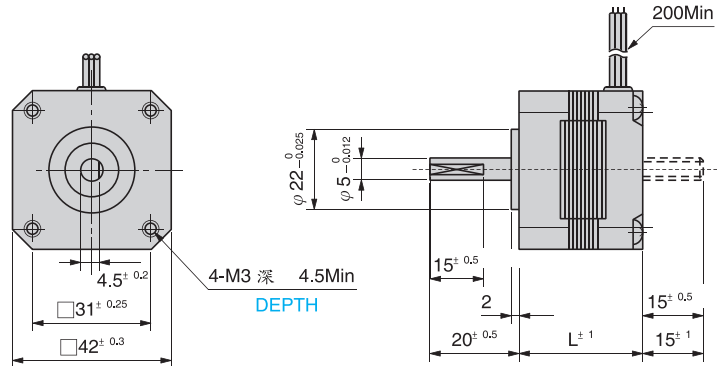
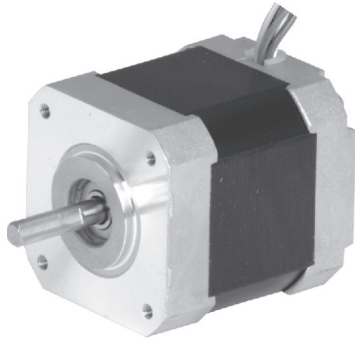

形式 Type number		基本步級角 Step Angle Deg.	額定電壓 Rated Voltage V/Phase	額定電流 Rated Current A/Phase	線圈阻抗 Winding Resistance Ω/Phase	線圈感抗 Inductance mH/Phase	激磁最大 靜止力矩 Holding Torque N-m(kgf·cm)	馬達長度L Motor Length mm	轉子慣量 Rotor Inertia x10 ⁻⁷ kg·m ²	質量 Mass g
單軸 Single Shaft	兩軸 Double Shaft									
TS3617N1E1	TS3617N11E1	1.8	4.0	0.95	4.2	2.8	0.16(1.6)	33	35	200
TS3617N1E2	TS3617N11E2	1.8	9.6	0.4	24	15	0.16(1.6)	33	35	200
TS3617N1E3	TS3617N11E3	1.8	12.0	0.3	40	22	0.16(1.6)	33	35	200
TS3617N2E4	TS3617N12E4	1.8	4.0	1.2	3.3	3.6	0.26(2.6)	39	54	240
TS3617N2E5	TS3617N12E5	1.8	6.4	0.8	8	7.6	0.26(2.6)	39	54	240
TS3617N2E6	TS3617N12E6	1.8	12	0.4	30	30	0.26(2.6)	39	54	240
TS3617N2E7	TS3617N12E7	1.8	24	0.2	120	106	0.26(2.6)	39	54	240
TS3617N3E8	TS3617N13E8	1.8	4.0	1.2	3.3	3	0.32(3.2)	47	68	310
TS3617N3E9	TS3617N13E9	1.8	7.2	0.8	9	9.5	0.32(3.2)	47	68	310
TS3617N3E10	TS3617N13E10	1.8	12	0.4	30	29	0.32(3.2)	47	68	310

●使用周圍溫度 ——— -20~+50°C
Operating temperature range

●絕緣阻抗 ——— 100MΩ Min(at DC500V)
Insulation resistance

●絕緣耐壓 ——— AC500V(1min)
Dielectric strength

●軸心平行方向移動量 — 0.075mm Max. (With 10N(1kgf)Load)
End play

●軸心垂直方向移動量 — 0.025mm Max. (With 5N(500gf)Load)
Radial play

●容許溫度上昇 ——— 80deg Max(Rasistance method)
Permissible temperature rise

※注意:馬達表面請保持在90°C以下

※NOTE: Do not allow the surface temperature of the motor case to rise above 90°C during operation.

結線圖

WIRING DIAGRAM

UNIPOLAR

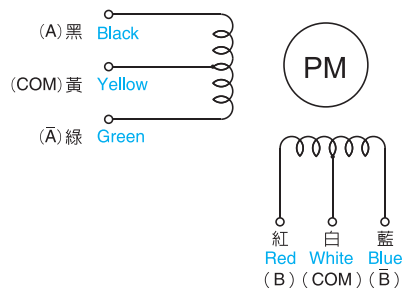

回轉方向：由出力軸目視之正轉方向

CW rotation from output shaft end.

Step	黑 Black	紅 Red	綠 Green	藍 Blue	黃 Yellow	白 White
0	ON	ON			COM	COM
1		ON	ON		COM	COM
2			ON	ON	COM	COM
3	ON			ON	COM	COM
0	ON	ON			COM	COM

42mm HB TYPE 高扭力 · 低振動

1.8° RoHS對應

Self-certification products, RoHS compliant products.

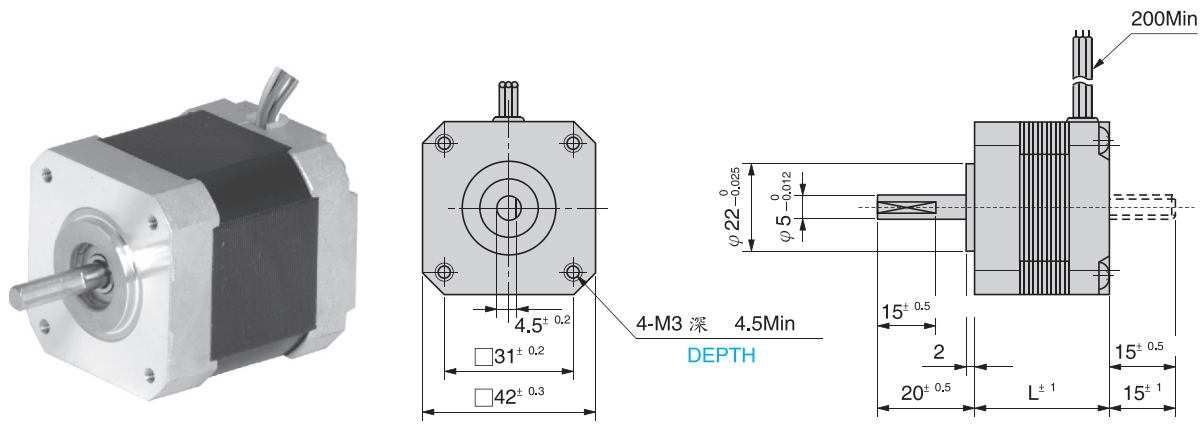

形式 Type number		基本步級角 Step Angle Deg.	額定電壓 Rated Voltage V/Phase	額定電流 Rated Current A/Phase	線圈阻抗 Winding Resistance Ω/Phase	線圈感抗 Inductance mH/Phase	激磁最大 靜止力矩 Holding Torque N·m(kgf·cm)	馬達長度L Motor Length mm	轉子慣量 Rotor Inertia x10 ⁻⁷ kg·m ²	質量 Mass g
單軸 Single Shaft	兩軸 Double Shaft									
TS3617N502	TS3617N602	1.8	4.8	1.2	4	3.3	0.35(3.5)	41	57	240
TS3617N503	TS3617N603	1.8	5.8	1.2	4.8	3.6	0.49(4.9)	49	76	310
TS3617N504	TS3617N604	1.8	7.2	1.2	6	6.5	0.75(7.5)	61	114	490

- 使用周圍溫度 ———— -20~+50°C
Operating temperature range
 - 絕緣阻抗 ———— 100MΩ Min(at DC500V)
Insulation resistance
 - 絕緣耐壓 ———— AC500V(1min)
Dielectric strength
 - 軸心平行方向移動量 — 0.075mm Max. (With 10N(1kgf)Load)
End play
 - 軸心垂直方向移動量 — 0.025mm Max. (With 5N(500gf)Load)
Radial play
 - 容許溫度上昇 ———— 80deg Max(Rasistance method)
Permissible temperature rise
- ※注意:馬達表面請保持在90°C以下
※NOTE: Do not allow the surface temperature of the motor case to rise above 90°C during operation.

結線圖 WIRING DIAGRAM

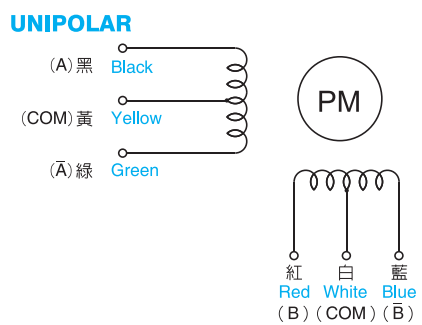

回轉方向：由出力軸目視之正轉方向
CW rotation from output shaft end.

Step	黑 Black	紅 Red	綠 Green	藍 Blue	黃 Yellow	白 White
0	ON	ON			COM	COM
1		ON	ON		COM	COM
2			ON	ON	COM	COM
3	ON			ON	COM	COM
0	ON	ON			COM	COM